

Opening in back wall cast to suit the outside diameter of the pipe at invert height required.

Note: Isometric drawing is for reference only, details may not accurately represent actual design - please see detailed views for technical information

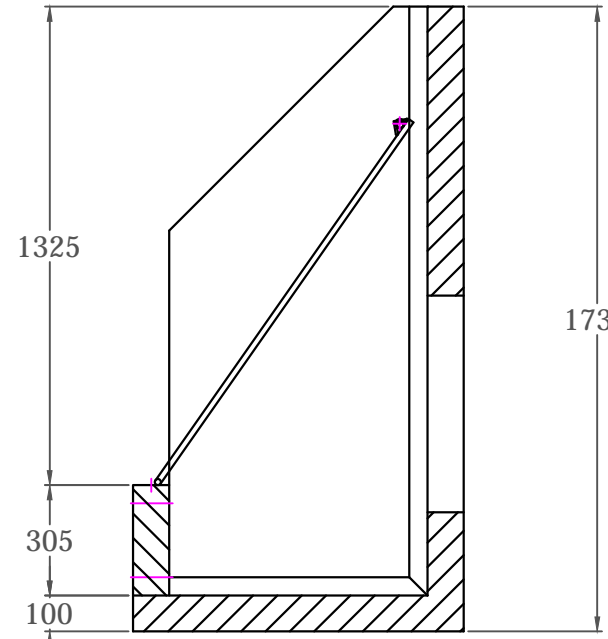
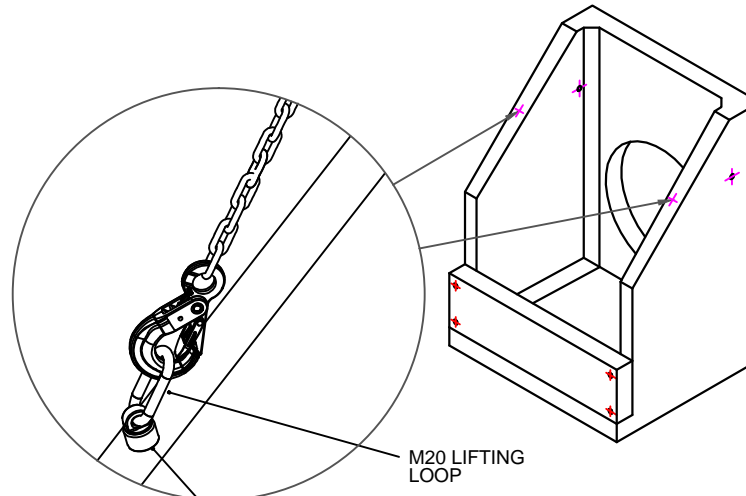
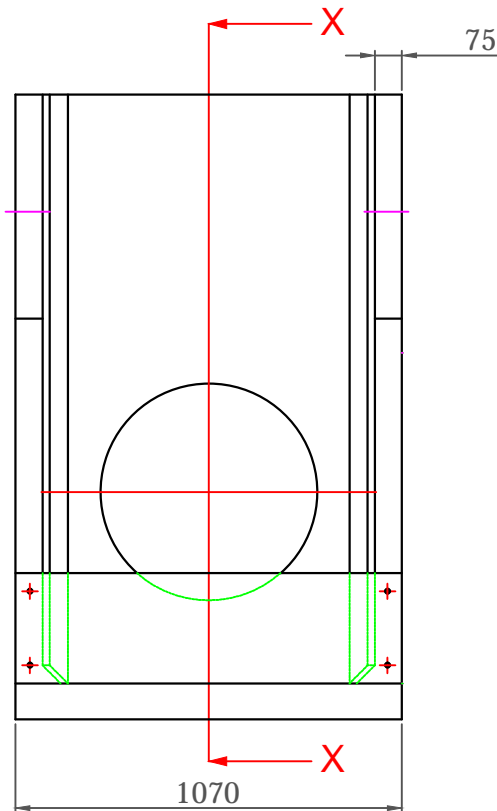
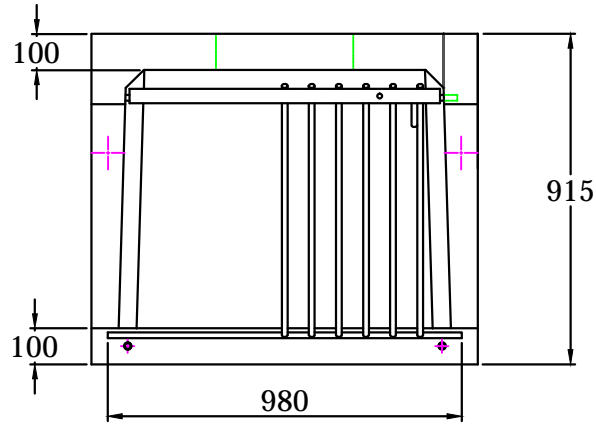

Section XX

DO NOT SCALE DRAWING

NOTES:

- All dimensions in mm U.O.S
- All measurements ± 1mm

Specification Information

- Opening in back wall cast to suit outside diameter of the pipework.
- Invert level of pipe can be set to your specification.

Headwall Installation

Units should be bedded on minimum 100mm thick well compacted Class 6A selected well graded granular material.
 *Manual of contract documents for Highway Works: Volume (MCHW1) specification for Highway Works, Series 600 (Nov.09).
 Sit the headwall level or with a slight fall 1:50 from pipe to spill mouth.

Handling

- Weight of concrete is based on 2.4 tonne/m³+5% is recommended for sizing lifting equipment.
- All lifting points shall be used as specified below.
- Unit to be lifted as per lifting diagram.

Concrete

- Mix ref: Self-Compacting DC4/DS4 Mix
- Lifting strength based on 2 cubes = 20N/mm²
- Characteristic 28 day cube strength = 50N/mm²
- Concrete provides Design Chemical Class 4 (DC4) to special Digest 1, Table F2.

Reinforcement

- Reinforcement to BS EN 13369.
- Scheduling, dimensioning, bending & cutting to BS8666.
- Cage to be machine tied with steel wire.

Manufacture

- Manufacture to BS EN 15258:2008 precast concrete products - Retaining wall elements, Factory Production Control Certificate number: 0086-CPR-650448 & BS EN 13369.
- Tolerances to BS EN 13369 clause 4.3.1.1

Finishing

	Top	Sides	Rear	Rear of back wall
Class	A	A	A	Self-Levelled
D. Marking: Units shall be indelibly marked to show:				
+ Mould Reference code.				
+ De-mould date.				
+ Job reference number & unique product number.				
+ Unit weight (kg)				

Design

- Concrete design to EC2.
- JKH have designed the concrete units only, the site conditions should be assessed for suitability by the scheme designer.
- Units are designed to withstand a vertical live load surcharge of 10kN/M².
- Weight of soil = 18kN/M².
- Angle of internal friction = 30°.
- Design Life: >50 years

Min Cover	Cover Block	Min Cover	Max Cover
Classification	by Carbonation	by Chloride	by Chloride
All Faces	33	28	38
	32/31	32/31	32/31

Fabrication Specification

- Manufacture IAW EN 1090-2 EXC CLASS 1
- Material grade is to be: BS EN 10025 S275
- Welding carried out IAW EN 1090-2 PARA 7.5.4 - 7.5.18
- All fillet and butt welds to have a minimum throat thickness of 6mm & joints to be fully welded where possible.
- Ensure vertical flats are fully welded both sides where possible.
- All sharp edges and burrs are to be removed.
- Remove all weld splatter.
- Holes by punching are permitted without reaming.
- Galvanising is carried out after fabrication to BS EN: ISO 1461.

Handrail Specification

- Kea Klamp Galvanised Size 8 Fittings.
- Size 8 48.3mm OD 3.2mm Wall Thickness Galvanised Medium Duty Tube to BS EN 10255.
- 360N/m Design Load as stated in BS 8118, BS 6180, BS 6399 & BS 7818, Civil Engineering Specification for the Water Industry (CESWI).
- Other design loads available on request
- GRP/FRP Handrails also available.

ADDRESS: JKH LIMITED
HAMPSTEAD AVENUE
MILDENHALL
IP28 7AS

TEL: 01638 713795
FAX: 01638 882507
EMAIL: info@jkh.co.uk
WEBSITE: www.jkhhd.co.uk

PROPRIETARY & CONFIDENTIAL

The information contained in this drawing is the sole property of JKH Drainage Units Limited.
No reproduction is permitted in any form without the written permission of JKH Drainage Units Limited in writing.

DRAWING TITLE / PROJECT:

**Type X Silt Trap
1730mm Tall**

CLIENT:	Client
SCALE:	NTS
DRAWING DATE:	17/07/2019
TOTAL WEIGHT:	14750kg
DRAWN BY:	LC
CHECKED BY:	-
DRAWING No:	

TYPE X SILT TRAP 1730

