

**DRAWING NOTES**

- All dimensions in mm U.O.S.
- All measurements ±1mm.
- DO NOT SCALE DRAWING.

**SPECIFICATION INFORMATION**

- Opening in back wall cast to suit outer dimension of pipe.
- Invert level of pipe can be set to your specification.

**HEADWALL INSTALLATION**

Units should be bedded on minimum 150mm thick well compacted Class 6N or 6K\* well graded granular material with 50mm topping of fine material (Class 6L\*) to ensure units are level and stable. \*Manual of contract documents for Highway Works: Volume (MCHW1) specification for Highway Works, Series 600 (Nov 09).

**HANDLING**

- Weight of concrete is based on 2.4 tonne/m<sup>3</sup> +5% is recommended for sizing lifting equipment.
- All lifting points shall be used as specified below
- Unit to be lifted as per lifting diagram.

**CONCRETE**

- Mix ref: Self-compacting DC4 / DS4 Mix.
- Lifting strength based on 2 cubes = 20N/mm<sup>2</sup>.
- Characteristic 28 day cube strength = 50N/mm<sup>2</sup>.
- Concrete provides Design Chemical Class 4 (DC4) to special Digest 1, Table F2.

**REINFORCEMENT**

- Reinforcement to BS EN 13369.
- Scheduling, dimensions, bends & cutting to BS8666.
- Cage to be machine tied with steel wire.

**MANUFACTURE**

- Manufacture to BS EN 15258:2008 precast concrete products retaining wall elements, factory production control certificate 0086-CPR-650448 & BS EN 13369.
- Tolerances to BS EN 13369 clause 4.3.1.1.
- Finishing:

Class	Tip	Sides	Rear	Rear of Backwall
	A	A	A	A

- Marking. Units shall be indelibly marked to show:
  - Mould reference code.
  - De-mould date.
  - Job reference number & unique product number.
  - Unit weight (kg).

**DESIGN**

- Concrete structure designed to Eurocode 2.
- JKH have designed concrete units only, the site conditions should be assessed for suitability by the scheme designer
- Units are designed to withstand a vertical live load surcharge of 10kN/m<sup>2</sup>.
- Weight of soil = 18kN/m<sup>3</sup>.
- Angle of internal friction = 30 Deg.
- Design Life as table below \* (all cover sizes in mm).

Design Life	>50 years, 100mm Wall Thickness		>100 years, 150mm Wall Thickness	
	Block Size Cover	Min Size Cover	Block Size Cover	Min Size Cover
Minimum Cover for All Faces	33	28	38	33
Maximum Cover for All Faces	50	50	50	63

\*Design life of >100 years can be extended to >120 years with Bitumen coating application

Exposure Classification	Corrosion induced by Chloride		Freeze/thaw attack		Chemical attack	
	Block Size Cover	Min Size Cover	Block Size Cover	Min Size Cover	Block Size Cover	Min Size Cover
All Faces	XC3/4	XD3	XF4	XF4	XA3	XA3

**FABRICATION SPECIFICATION**

- Manufacture IAW EN 1090-2 EXC CLASS 1
- Material grade is to be: BS EN 10025 S275
- Welding to IAW EN 1090-2 PARA 7.5.4 - 7.5.18
- All fillet & butt welds to have minimum throat thickness of 6mm and joints fully welded where possible.
- Ensure vertical flats fully welded both sides where possible
- All sharp edges and burrs are to be removed.
- Remove all weld splatter.
- Holes by punching are permitted with reaming.
- Galvanising process after fabrication to BS EN ISO1461.

**HANDRAIL SPECIFICATION**

- Keel Klamp® Galvanised Size 8 Fittings.
- Size 8 48.3mm OD 3.2mm Wall Thickness Galvanised Medium Duty Tube to BS EN 10255
- 360N/m Design Load as stated in BS 8118, BS 6180, BS 6399 & BS 7818, Civil Engineering Specification for the Water Industry (CESWI) 7th Edition Clause 2.60 Handrails & Balusters & The Engineering Equipment and Materials Users' Association (EEMUA) Publication 105 7th Edition Factory Stairways, Ladders and Handrails.
- Other design loads available on request.
- GRP/FRP Handrails also available.

ADDRESS: JKH LIMITED  
CHISWICK AVENUE  
MILDENHALL  
IP28 7AY

WEBSITE: [www.jkhld.co.uk](http://www.jkhld.co.uk)  
EMAIL: [sales@jkhld.co.uk](mailto:sales@jkhld.co.uk)  
TEL: 01638 713795

**PROPRIETARY & CONFIDENTIAL** Information contained on this drawing is the sole property of JKH Drainage Units Ltd. Any reproduction in part or as a whole without the written permission of JKH Drainage Units Ltd is strictly prohibited.

**DRAWING TITLE:**

**XR2000 A HEADWALL  
STANDARD & OPTIONAL FEATURES**

**TOTAL WEIGHT (CASTINGS ONLY):** 2645 kg

**CONCRETE MIX DESIGN:**

eco 1

CEMENT REDUCTION **↓ -46%**

**STANDARD FEATURES**

**OPENING SIZE GUIDE**

Ø 1020mm  
MAXIMUM OPENING

TYPICAL MAXIMUM PIPE SIZES\*  
PLASTIC TWINWALL I.D. Ø 750mm  
CONCRETE I.D. Ø 750mm

**CUSTOM DESIGN  
BESPOKE SOLUTIONS...**

- CONCRETE
- STEELWORK
- HANDRAILS
- FLOW CONTROL

**100 YEAR DESIGN LIFE**

**CAST-IN S/S SOCKETS  
ACCURATE ALIGNMENT TO JOINT  
FITTINGS & OPTIONAL FEATURES**

**OPTIONAL FEATURES**

**TOE BEAM RANGE**

VARIOUS SIZE OPTIONS ARE AVAILABLE

**CONCRETE COLOURS**

24 COLOURS AVAILABLE IN RANGE FOR BLENDING ITEM WITH LOCAL ENVIRONMENT

**GRATINGS & TRASH SCREENS**

FACTORY FITTED AS STANDARD \*WHERE PRACTICAL / SAFE FOR TRANSPORT

- FULLY WELDED, HOT DIP GALVANISED STEEL & S/S FIXINGS AS STANDARD

• CLOSE COUPLED • SFA / SSG OUTFALL GRILLE • SLOPED • CRANKED

**KEE KLAMP HANDRAILS**

FACTORY FITTED AS STANDARD \*WHERE PRACTICAL / SAFE FOR TRANSPORT

• KEE KLAMP #8 AS STANDARD • FULLY SIDED (CODE: K30) • HALF WING (CODE: K50) • BACK ONLY (CODE: K00)

**FLOW CONTROL DEVICES**

FACTORY FITTED (WHERE PRACTICAL / SAFE FOR TRANSPORT) AS STANDARD

- S/S FIXINGS & RUBBER SEALS / SEALANTS AS STANDARD

• FLAP VALVES • PENSTOCKS • ORIFICE PLATES • BAFFLE BLOCKS

**ALUMINIUM STOPLOG SYSTEM**

CHANNELS FACTORY FITTED AS STANDARD \*WHERE PRACTICAL / SAFE FOR TRANSPORT

- VARIOUS BOARD HEIGHT / TYPES AVAILABLE
- LOCKING BRACKETS & T-KEY KITS SUPPLIED, S/S FIXINGS & RUBBER SEALS AS STANDARD

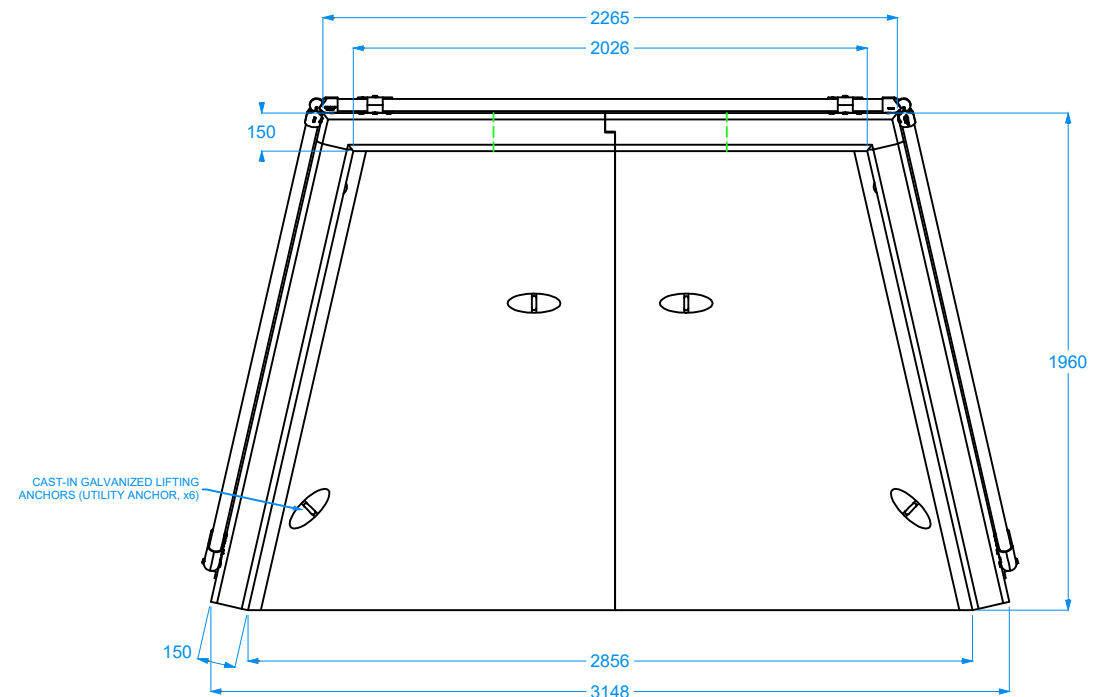

VIEW: TOP

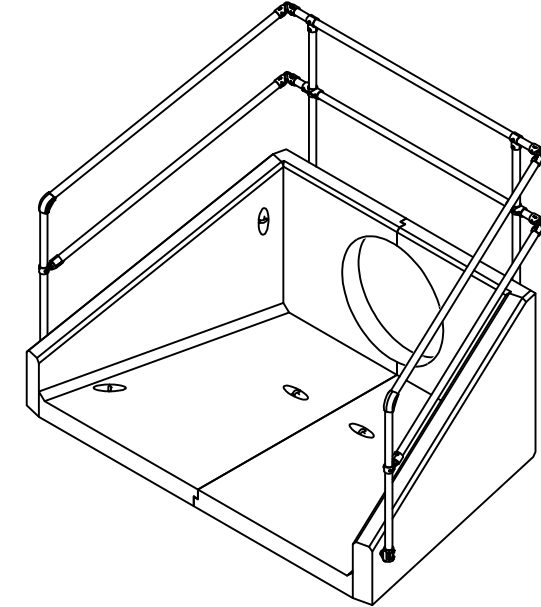

VIEW: ISOMETRIC

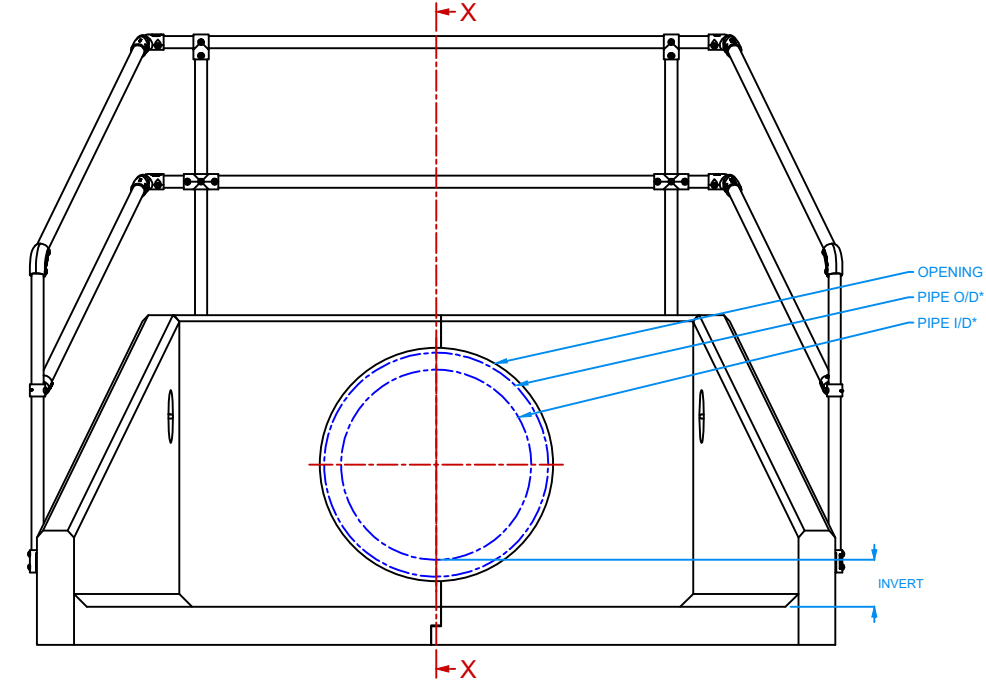

VIEW: FRONT

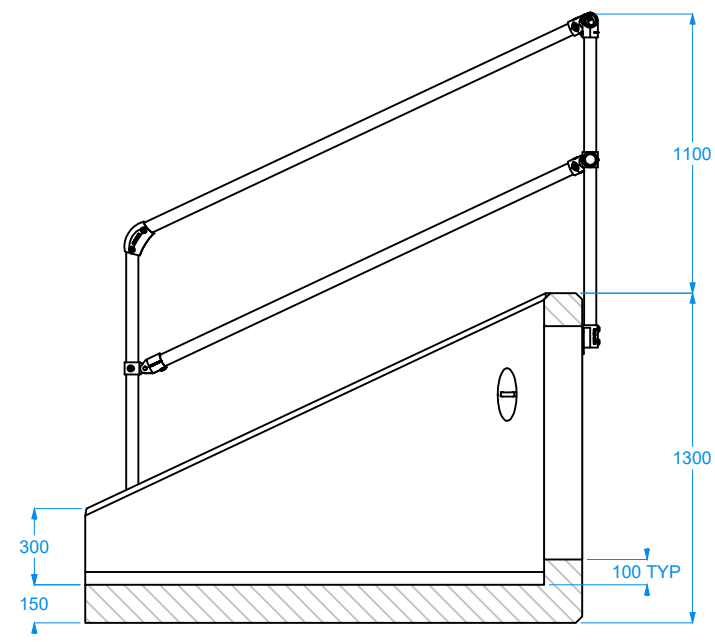

VIEW: SECTION

**DRAWING NOTES**

- All dimensions in mm U.O.S.
- All measurements ±1mm.
- DO NOT SCALE DRAWING.

**SPECIFICATION INFORMATION**

- Opening in back wall cast to suit outer dimension of pipe.
- Invert level of pipe can be set to your specification.

**HEADWALL INSTALLATION**

Units should be bedded on minimum 150mm thick well compacted Class 6N or 6K\* well graded granular material with 50mm topping of fine material (Class 6L\*) to ensure units are level and stable. \*Manual of contract documents for Highway Works: Volume (MCHW1) specification for Highway Works, Series 600 (Nov 09).

**HANDLING**

- Weight of concrete is based on 2.4 tonne/m<sup>3</sup> +5% is recommended for sizing lifting equipment.
- All lifting points shall be used as specified below
- Unit to be lifted as per lifting diagram.

**CONCRETE**

- Mix ref: Self-compacting DC4 / DS4 Mix.
- Lifting strength based on 2 cubes = 20N/mm<sup>2</sup>.
- Characteristic 28 day cube strength = 50N/mm<sup>2</sup>.
- Concrete provides Design Chemical Class 4 (DC4) to special Digest 1, Table F2.

**REINFORCEMENT**

- Reinforcement to BS EN 13369.
- Scheduling, dimensions, bends & cutting to BS8666.
- Cage to be machine tied with steel wire.

**MANUFACTURE**

- Manufacture to BS EN 15258:2008 precast concrete products retaining wall elements, factory production control certificate 0086-CPR-650448 & BS EN 13369.
- Tolerances to BS EN 13369 clause 4.3.1.1.
- Finishing:

Class	Top	Sides	Rear	Rear of Backwall
	A	A	A	Self-Levelled
Class	A	A	A	Self-Levelled

- Marking. Units shall be indelibly marked to show:
  - Mould reference code.
  - De-mould date.
  - Job reference number & unique product number.
  - Unit weight (kg).

**DESIGN**

- Concrete structure designed to Eurocode 2.
- JKH have designed concrete units only, the site conditions should be assessed for suitability by the scheme designer
- Units are designed to withstand a vertical live load surcharge of 10kN/m<sup>2</sup>.
- Weight of soil = 18kN/m<sup>3</sup>.
- Angle of internal friction = 30 Deg.
- Design Life as table below \* (all cover sizes in mm).

Design Life	>50 years, 100mm Wall Thickness		>100 years, 150mm Wall Thickness	
	Minimum Cover for All Faces	Maximum Cover for All Faces	Minimum Cover for All Faces	Maximum Cover for All Faces
33	28	38	55	63

\*Design life of >100 years can be extended to >120 years with Bitumen coating application

Exposure Classification	Exposure induced by Carbonation	Corrosion induced by Chloride	Freeze/thaw attack	Chemical attack
All Faces	XC3/4	XD3	XF4	XA3

**FABRICATION SPECIFICATION**

- Manufacture IAW EN 1090-2 EXC CLASS 1
- Material grade is to be: BS EN 10025 S275
- Welding to IAW EN 1090-2 PARA 7.5.4 - 7.5.18
- All fillet & butt welds to have minimum throat thickness of 6mm and joints fully welded where possible.
- Ensure vertical flats fully welded both sides where possible
- All sharp edges and burrs are to be removed.
- Remove all weld splatter.
- Holes by punching are permitted with reaming.
- Galvanising process after fabrication to BS EN ISO1461.

**HANDRAIL SPECIFICATION**

- Keel Klamp® Galvanised Size 8 Fixings.
- Size 8 48.3mm OD 3.2mm Wall Thickness Galvanised Medium Duty Tube to BS EN 10255
- 360N/m Design Load as stated in BS 8118, BS 6180, BS 6399 & BS 7818, Civil Engineering Specification for the Water Industry (CESWI) 7th Edition Clause 2.60 Handrails & Balusters & The Engineering Equipment and Materials Users' Association (EEMUA) Publication 105 7th Edition Factory Stairways, Ladders and Handrails.
- Other design loads available on request.
- GRP/FRP Handrails also available.



ADDRESS: JKH LIMITED  
CHISWICK AVENUE  
MILDENHALL  
IP28 7AY

WEBSITE: www.jkhld.co.uk  
EMAIL: sales@jkhld.co.uk  
TEL: 01638 713795

PROPRIETARY & CONFIDENTIAL. Information contained on this drawing is the sole property of JKH Drainage Units Ltd. Any reproduction in part or as a whole without the written permission of JKH Drainage Units Ltd is strictly prohibited.

DRAWING TITLE:

**XR2000 A LW HEADWALL  
STANDARD & OPTIONAL FEATURES**

TOTAL WEIGHT (CASTINGS ONLY): **4380 kg**

CONCRETE MIX DESIGN:

**ECO 1**  
CEMENT  
REDUCTION **-46%**

DRAWN: OB | ISSUE #: 01 | SHEET #: 1 of 1 | DATE: 10/07/25

DRAWING #: **XR2000ALW**

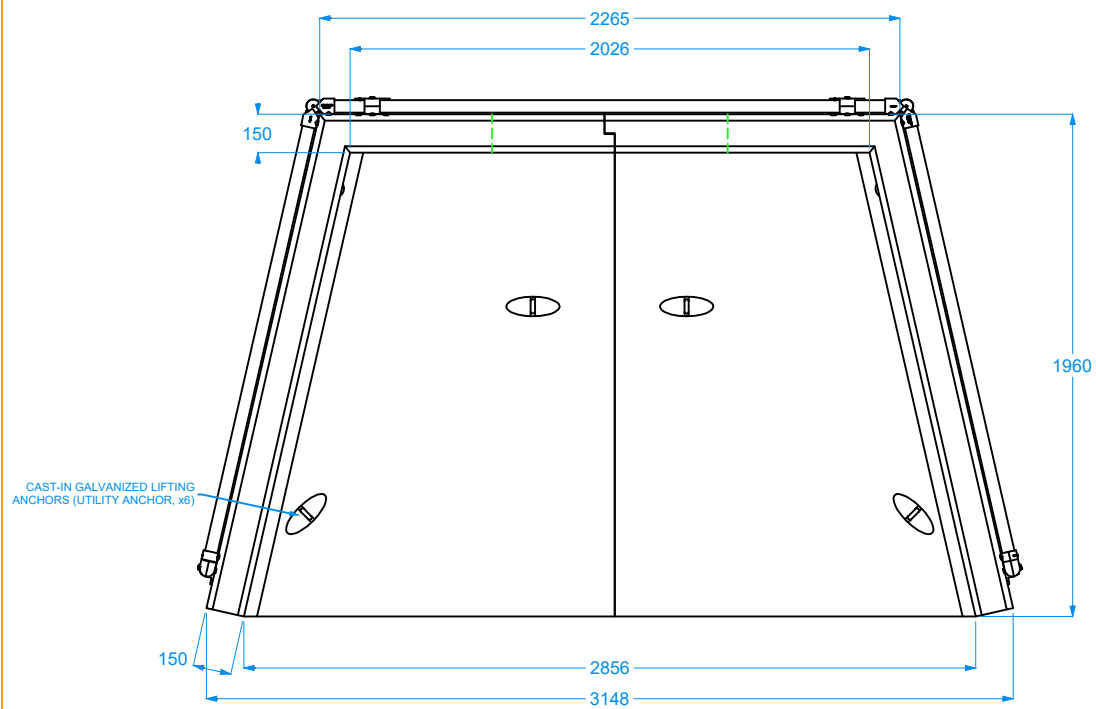

VIEW: TOP

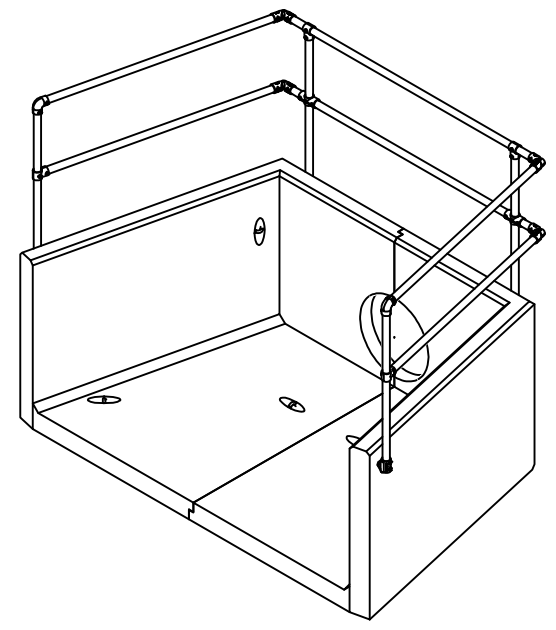

VIEW: ISOMETRIC

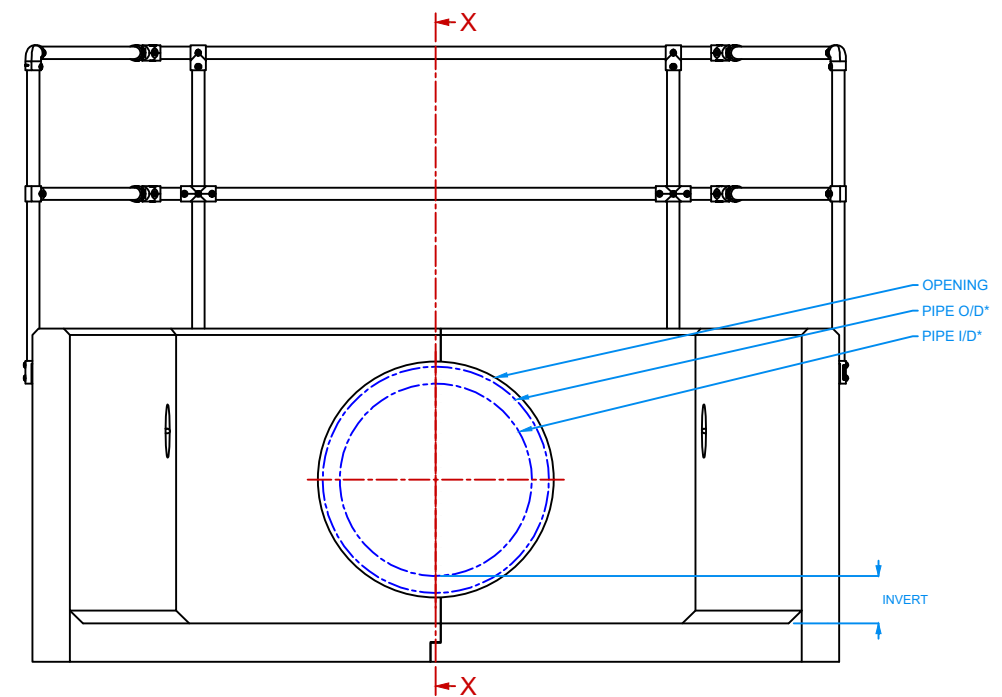

VIEW: FRONT

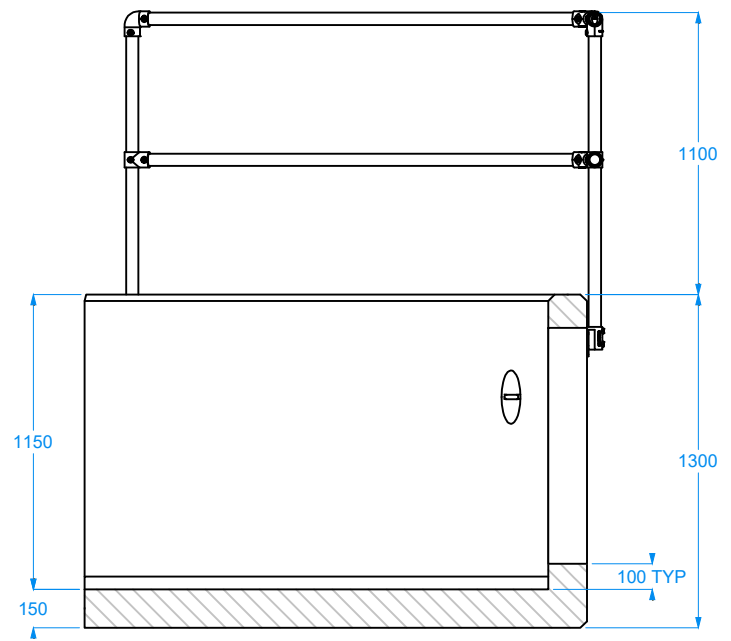

VIEW: SECTION

**STANDARD FEATURES**

**OPENING SIZE GUIDE**



Ø 1020mm  
MAXIMUM  
OPENING

TYPICAL MAXIMUM PIPE SIZES\*  
PLASTIC TWINWALL I/D: Ø 750mm  
CONCRETE I/D: Ø 750mm

**CUSTOM DESIGN  
BESPOKE SOLUTIONS...**

- CONCRETE
- STEELWORK
- HANDRAILS
- FLOW CONTROL

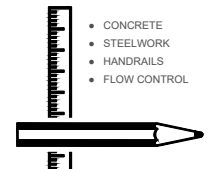

**100  
YEAR  
DESIGN LIFE**



**CAST-IN S/S SOCKETS**  
ACCURATE ALIGNMENT TO JOINT  
FITTINGS & OPTIONAL FEATURES

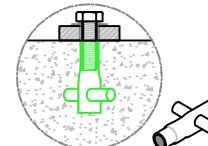

**OPTIONAL FEATURES**

**TOE BEAM RANGE**

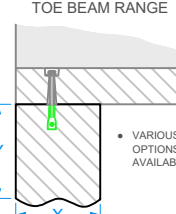

VARIOUS SIZE  
OPTIONS ARE  
AVAILABLE

**CONCRETE COLOURS**

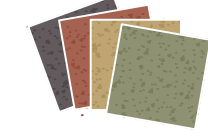





24 COLOURS AVAILABLE IN  
RANGE FOR BLENDING ITEM  
WITH LOCAL ENVIRONMENT

**GRATINGS & TRASH SCREENS**

FACTORY FITTED AS STANDARD \*WHERE PRACTICAL / SAFE FOR TRANSPORT

- FULLY WELDED, HOT DIP GALVANISED STEEL & S/S FIXINGS AS STANDARD









- CLOSE COUPLED
- SFA / SSG OUTFALL GRILLE
- SLOPED
- CRANKED

**KEE KLAMP HANDRAILS**

FACTORY FITTED AS STANDARD \*WHERE PRACTICAL / SAFE FOR TRANSPORT











- KEE KLAMP #8 AS STANDARD
- FULLY SIDED (CODE: K30)
- HALF WING (CODE: K50)
- BACK ONLY (CODE: K00)

**FLOW CONTROL DEVICES**

FACTORY FITTED (WHERE PRACTICAL / SAFE FOR TRANSPORT) AS STANDARD

- S/S FIXINGS & RUBBER SEALS / SEALANTS AS STANDARD

- FLAP VALVES
- PENSTOCKS
- ORIFICE PLATES
- BAFFLE BLOCKS

**ALUMINIUM STOPLOG SYSTEM**

CHANNELS FACTORY FITTED AS STANDARD \*WHERE PRACTICAL / SAFE FOR TRANSPORT

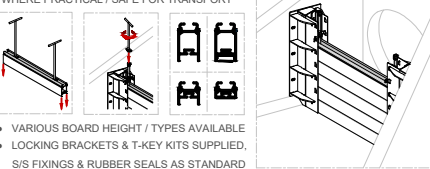

- VARIOUS BOARD HEIGHT / TYPES AVAILABLE
- LOCKING BRACKETS & T-KEY KITS SUPPLIED, S/S FIXINGS & RUBBER SEALS AS STANDARD

**DRAWING NOTES**

- All dimensions in mm U.O.S.
- All measurements ±1mm.
- DO NOT SCALE DRAWING.

**SPECIFICATION INFORMATION**

- Opening in back wall cast to suit outer dimension of pipe.
- Invert level of pipe can be set to your specification.

**HEADWALL INSTALLATION**

Units should be bedded on minimum 150mm thick well compacted Class 6N or 6K\* well graded granular material with 50mm topping of fine material (Class 6L\*) to ensure units are level and stable. \*Manual of contract documents for Highway Works: Volume (MCHW1) specification for Highway Works, Series 600 (Nov 09).

**HANDLING**

- Weight of concrete is based on 2.4 tonne/m<sup>3</sup> +5% is recommended for sizing lifting equipment.
- All lifting points shall be used as specified below
- Unit to be lifted as per lifting diagram.

**CONCRETE**

- Mix ref: Self-compacting DC4 / DS4 Mix.
- Lifting strength based on 2 cubes = 20N/mm<sup>2</sup>.
- Characteristic 28 day cube strength = 50N/mm<sup>2</sup>.
- Concrete provides Design Chemical Class 4 (DC4) to special Digest 1, Table F2.

**REINFORCEMENT**

- Reinforcement to BS EN 13369.
- Scheduling, dimensions, bends & cutting to BS8666.
- Cage to be machine tied with steel wire.

**MANUFACTURE**

- Manufacture to BS EN 15258:2008 precast concrete products retaining wall elements, factory production control certificate 0086-CPR-650448 & BS EN 13369.
- Tolerances to BS EN 13369 clause 4.3.1.1.
- Finishing:

Class	Top	Sides	Rear	Rear of Backwall
	A	A	A	A

- Marking. Units shall be indelibly marked to show:
  - Mould reference code.
  - De-mould date.
  - Job reference number & unique product number.
  - Unit weight (kg).

**DESIGN**

- Concrete structure designed to Eurocode 2.
- JKH have designed concrete units only, the site conditions should be assessed for suitability by the scheme designer
- Units are designed to withstand a vertical live load surcharge of 10kN/m<sup>2</sup>.
- Weight of soil = 18kN/m<sup>3</sup>.
- Angle of internal friction = 30 Deg.
- Design Life as table below \* (all cover sizes in mm).

Design Life	>50 years, 100mm Wall Thickness		>100 years, 150mm Wall Thickness	
	Block Size Cover	Min Size Cover	Block Size Cover	Min Size Cover
Minimum Cover for All Faces	33	28	38	33
Maximum Cover for All Faces	55	50	63	58

\*Design life of >100 years can be extended to >120 years with Bitumen coating application

Exposure Classification	Exposure induced by Carbonation	Corrosion induced by Chloride	Freeze/thaw attack	Chemical attack
All Faces	XC3/4	XD3	XF4	XA3

**FABRICATION SPECIFICATION**

- Manufacture IAW EN 1090-2 EXC CLASS 1
- Material grade is to be: BS EN 10025 S275
- Welding to IAW EN 1090-2 PARA 7.5.4 - 7.5.18
- All fillet & butt welds to have minimum throat thickness of 6mm and joints fully welded where possible.
- Ensure vertical flats fully welded both sides where possible
- All sharp edges and burrs are to be removed.
- Remove all weld splatter.
- Holes by punching are permitted with reaming.
- Galvanising process after fabrication to BS EN ISO1461.

**HANDRAIL SPECIFICATION**

- Keel Klamp® Galvanised Size 8 Fixings.
- Size 8 48.3mm OD 3.2mm Wall Thickness Galvanised Medium Duty Tube to BS EN 10255
- 360N/m Design Load as stated in BS 8118, BS 6180, BS 6399 & BS 7818, Civil Engineering Specification for the Water Industry (CESWI) 7th Edition Clause 2.60 Handrails & Balusters & The Engineering Equipment and Materials Users' Association (EEMUA) Publication 105 7th Edition Factory Stairways, Ladders and Handrails.
- Other design loads available on request.
- GRP/FRP Handrails also available.



ADDRESS: JKH LIMITED  
CHISWICK AVENUE  
MILDENHALL  
IP28 7AY

WEBSITE: www.jkhld.co.uk  
EMAIL: sales@jkhld.co.uk  
TEL: 01638 713795

**PROPRIETARY & CONFIDENTIAL** Information contained on this drawing is the sole property of JKH Drainage Units Ltd. Any reproduction in part or as a whole without the written permission of JKH Drainage Units Ltd is strictly prohibited.

**DRAWING TITLE:**

**XR2000 B HEADWALL  
STANDARD & OPTIONAL FEATURES**

TOTAL WEIGHT (CASTINGS ONLY): **4675 kg**

CONCRETE MIX DESIGN:

**eco 1**

CEMENT  
REDUCTION **-46%**

DRAWN: OB | ISSUE #: 01 | SHEET #: 1 of 1 | DATE: 10/07/25  
DRAWING #:  
**XR2000B**

**STANDARD FEATURES**

**OPENING SIZE GUIDE**

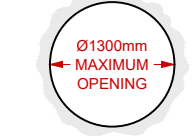

Ø1300mm  
← MAXIMUM OPENING →

TYPICAL MAXIMUM PIPE SIZES\*  
PLASTIC TWINWALL I/D: Ø1050mm  
CONCRETE I/D: Ø1050mm

**CUSTOM DESIGN  
BESPOKE SOLUTIONS...**

- CONCRETE
- STEELWORK
- HANDRAILS
- FLOW CONTROL

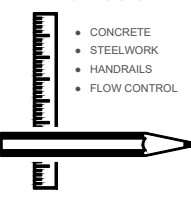

**100 YEAR DESIGN LIFE**



**CAST-IN S/S SOCKETS**  
ACCURATE ALIGNMENT TO JOINT FITTINGS & OPTIONAL FEATURES

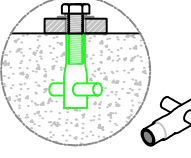

**OPTIONAL FEATURES**

**TOE BEAM RANGE**

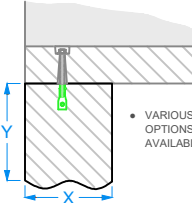

• VARIOUS SIZE OPTIONS ARE AVAILABLE

**CONCRETE COLOURS**

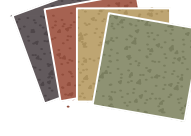



• 24 COLOURS AVAILABLE IN RANGE FOR BLENDING ITEM WITH LOCAL ENVIRONMENT

**GRATINGS & TRASH SCREENS**

FACTORY FITTED AS STANDARD \*WHERE PRACTICAL / SAFE FOR TRANSPORT

- FULLY WELDED, HOT DIP GALVANISED STEEL & S/S FIXINGS AS STANDARD







- CLOSE COUPLED
- SFA / SSG OUTFALL GRILLE
- SLOPED
- CRANKED

**KEE KLAMP HANDRAILS**

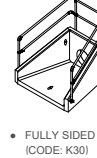
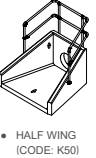
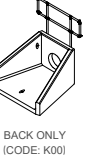
FACTORY FITTED AS STANDARD \*WHERE PRACTICAL / SAFE FOR TRANSPORT









- KEE KLAMP #8 AS STANDARD
- FULLY SIDED (CODE: K30)
- HALF WING (CODE: K50)
- BACK ONLY (CODE: K00)

**FLOW CONTROL DEVICES**

FACTORY FITTED (WHERE PRACTICAL / SAFE FOR TRANSPORT) AS STANDARD

- S/S FIXINGS & RUBBER SEALS / SEALANTS AS STANDARD

- FLAP VALVES
- PENSTOCKS
- ORIFICE PLATES
- BAFFLE BLOCKS

**ALUMINIUM STOPLOG SYSTEM**

CHANNELS FACTORY FITTED AS STANDARD \*  
\*WHERE PRACTICAL / SAFE FOR TRANSPORT

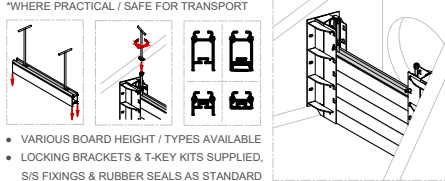

- VARIOUS BOARD HEIGHT / TYPES AVAILABLE
- LOCKING BRACKETS & T-KEY KITS SUPPLIED, S/S FIXINGS & RUBBER SEALS AS STANDARD

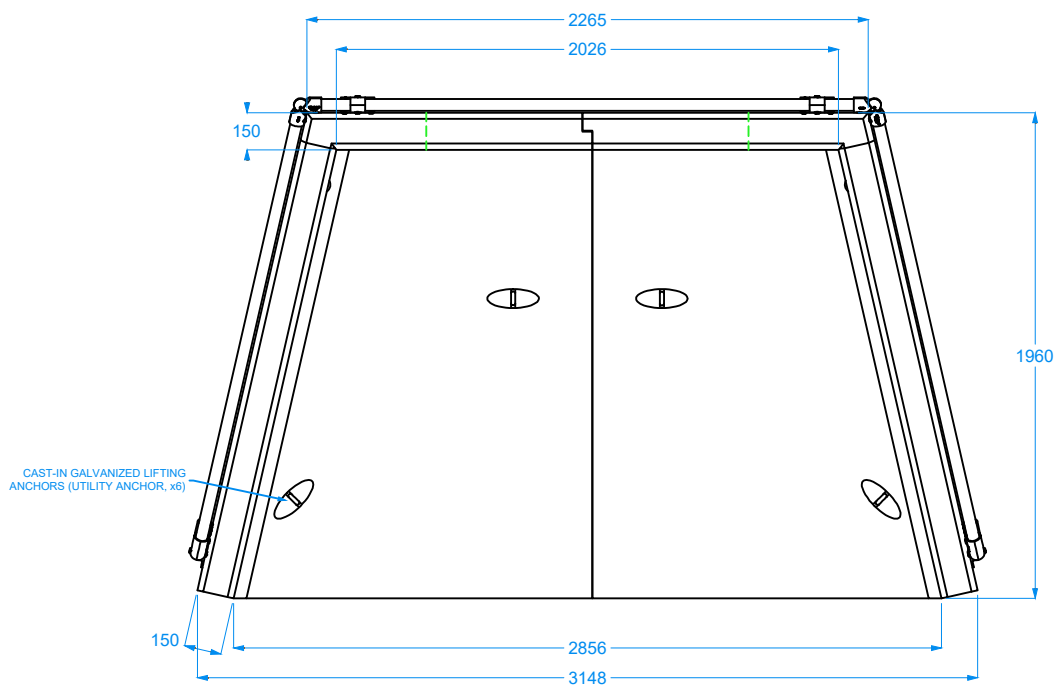

VIEW: TOP

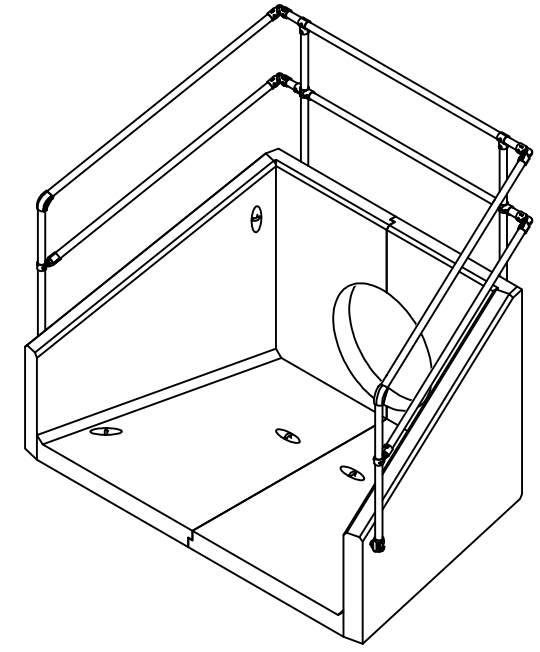

VIEW: ISOMETRIC

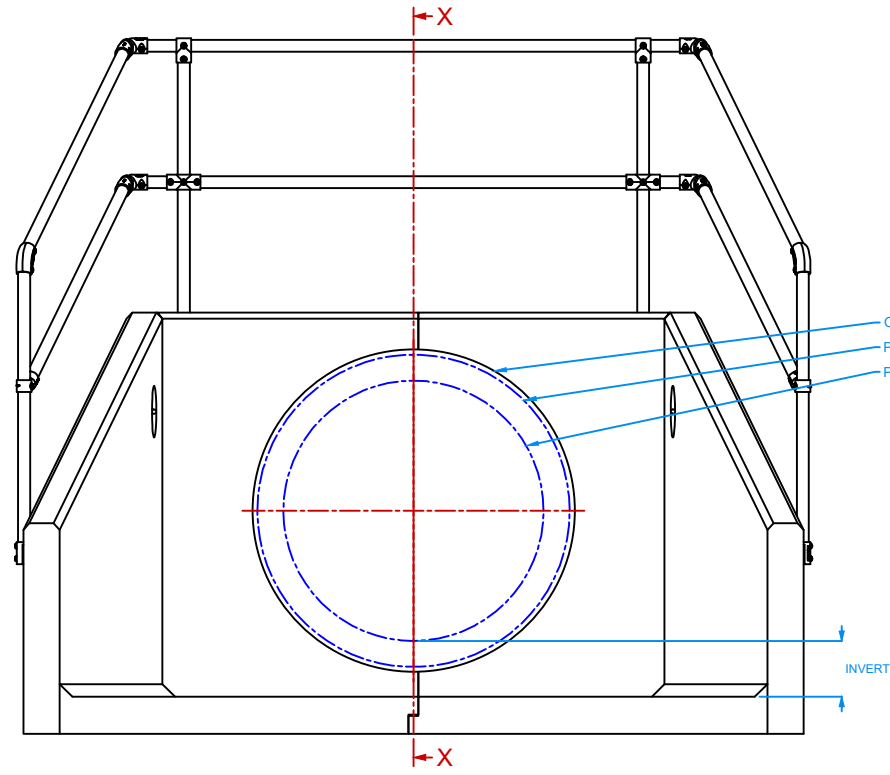

VIEW: FRONT

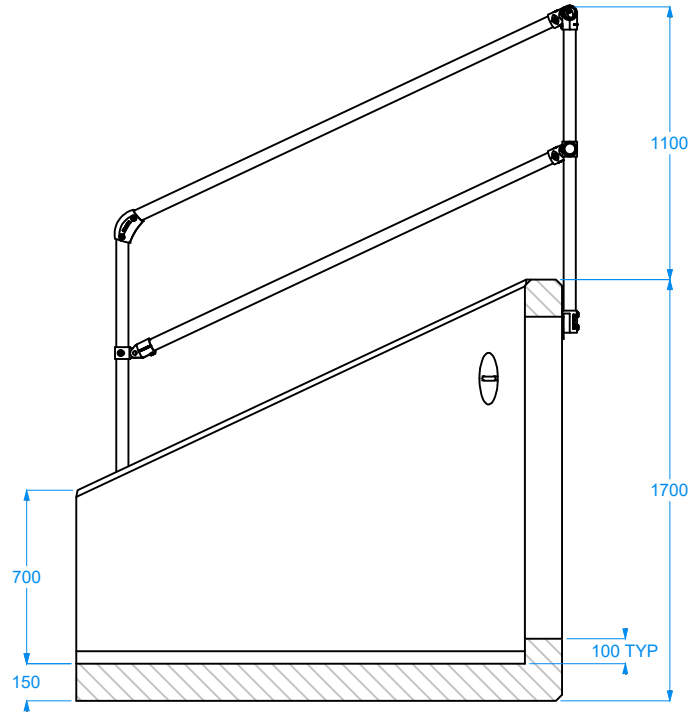

VIEW: SECTION X-X

**DRAWING NOTES**

- All dimensions in mm U.O.S.
- All measurements ±1mm.
- DO NOT SCALE DRAWING.

**SPECIFICATION INFORMATION**

- Opening in back wall cast to suit outer dimension of pipe.
- Invert level of pipe can be set to your specification.

**HEADWALL INSTALLATION**

Units should be bedded on minimum 150mm thick well compacted Class 6N or 6K\* well graded granular material with 50mm topping of fine material (Class 6L\*) to ensure units are level and stable. \*Manual of contract documents for Highway Works: Volume (MCHW1) specification for Highway Works, Series 600 (Nov 09).

**HANDLING**

- Weight of concrete is based on 2.4 tonne/m<sup>3</sup> +5% is recommended for sizing lifting equipment.
- All lifting points shall be used as specified below
- Unit to be lifted as per lifting diagram.

**CONCRETE**

- Mix ref: Self-compacting DC4 / DS4 Mix.
- Lifting strength based on 2 cubes = 20N/mm<sup>2</sup>.
- Characteristic 28 day cube strength = 50N/mm<sup>2</sup>.
- Concrete provides Design Chemical Class 4 (DC4) to special Digest 1, Table F2.

**REINFORCEMENT**

- Reinforcement to BS EN 13369.
- Scheduling, dimensions, bends & cutting to BS8666.
- Cage to be machine tied with steel wire.

**MANUFACTURE**

- Manufacture to BS EN 15258:2008 precast concrete products retaining wall elements, factory production control certificate 0086-CPR-650448 & BS EN 13369.
- Tolerances to BS EN 13369 clause 4.3.1.1.
- Finishing:

Class	Tip	Sides	Rear	Rear of Backwall
	A	A	A	A

- Marking. Units shall be indelibly marked to show:
  - Mould reference code.
  - De-mould date.
  - Job reference number & unique product number.
  - Unit weight (kg).

**DESIGN**

- Concrete structure designed to Eurocode 2.
- JKH have designed concrete units only, the site conditions should be assessed for suitability by the scheme designer
- Units are designed to withstand a vertical live load surcharge of 10kN/m<sup>2</sup>.
- Weight of soil = 18kN/m<sup>2</sup>.
- Angle of internal friction = 30 Deg.
- Design Life as table below \* (all cover sizes in mm).

Design Life	>50 years, 100mm Wall Thickness		>100 years, 150mm Wall Thickness	
	Block Size Cover	Min Size Cover	Block Size Cover	Min Size Cover
Minimum Cover for All Faces	33	28	38	33
			55	50
				63

\*Design life of >100 years can be extended to >120 years with Bitumen coating application

Exposure Classification	Exposure induced by Carbonation	Corrosion induced by Chloride	Freeze/thaw attack	Chemical attack
	All Faces	XC3/4	XD3	XF4

**FABRICATION SPECIFICATION**

- Manufacture IAW EN 1090-2 EXC CLASS 1
- Material grade is to be: BS EN 10025 S275
- Welding to IAW EN 1090-2 PARA 7.5.4 - 7.5.18
- All fillet & butt welds to have minimum throat thickness of 6mm and joints fully welded where possible.
- Ensure vertical flats fully welded both sides where possible
- All sharp edges and burrs are to be removed.
- Remove all weld splatter.
- Holes by punching are permitted with reaming.
- Galvanising process after fabrication to BS EN ISO1461.

**HANDRAIL SPECIFICATION**

- Kee Klamp® Galvanised Size 8 Fittings.
- Size 8 48.3mm OD 3.2mm Wall Thickness Galvanised Medium Duty Tube to BS EN 10255
- 360N/m Design Load as stated in BS 8118, BS 6180, BS 6399 & BS 7818, Civil Engineering Specification for the Water Industry (CESWI) 7th Edition Clause 2.60 Handrails & Balusters & The Engineering Equipment and Materials Users' Association (EEMUA) Publication 105 7th Edition Factory Stairways, Ladders and Handrails.
- Other design loads available on request.
- GRP/FRP Handrails also available.

ADDRESS: JKH LIMITED  
CHISWICK AVENUE  
MILDENHALL  
IP28 7AY

WEBSITE: [www.jkhlimited.co.uk](http://www.jkhlimited.co.uk)  
EMAIL: [sales@jkhlimited.co.uk](mailto:sales@jkhlimited.co.uk)  
TEL: 01638 713795

**PROPRIETARY & CONFIDENTIAL** Information contained on this drawing is the sole property of JKH Drainage Units Ltd. Any reproduction in part or as a whole without the written permission of JKH Drainage Units Ltd is strictly prohibited.

**DRAWING TITLE:**

**XR2000 B LW HEADWALL  
STANDARD & OPTIONAL FEATURES**

TOTAL WEIGHT (CASTINGS ONLY): **5240 kg**

CONCRETE MIX DESIGN:

**ECO 1**

CEMENT  
REDUCTION **-46%**

DRAWN: OB | ISSUE #: 01 | SHEET #: 1 of 1 | DATE: 10/07/25  
DRAWING #:  
**XR2000BLW**

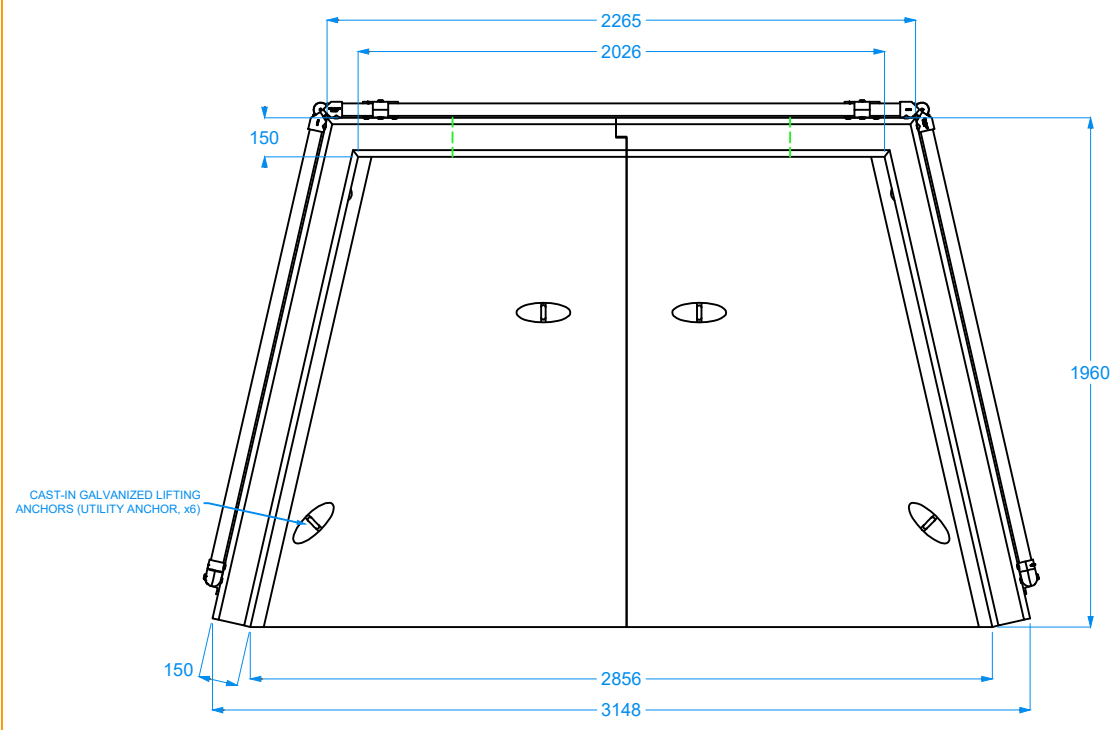

VIEW: TOP

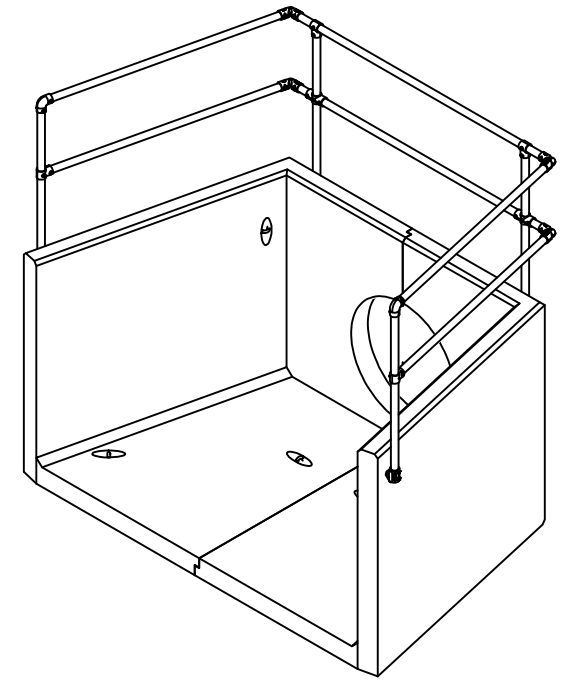

VIEW: ISOMETRIC

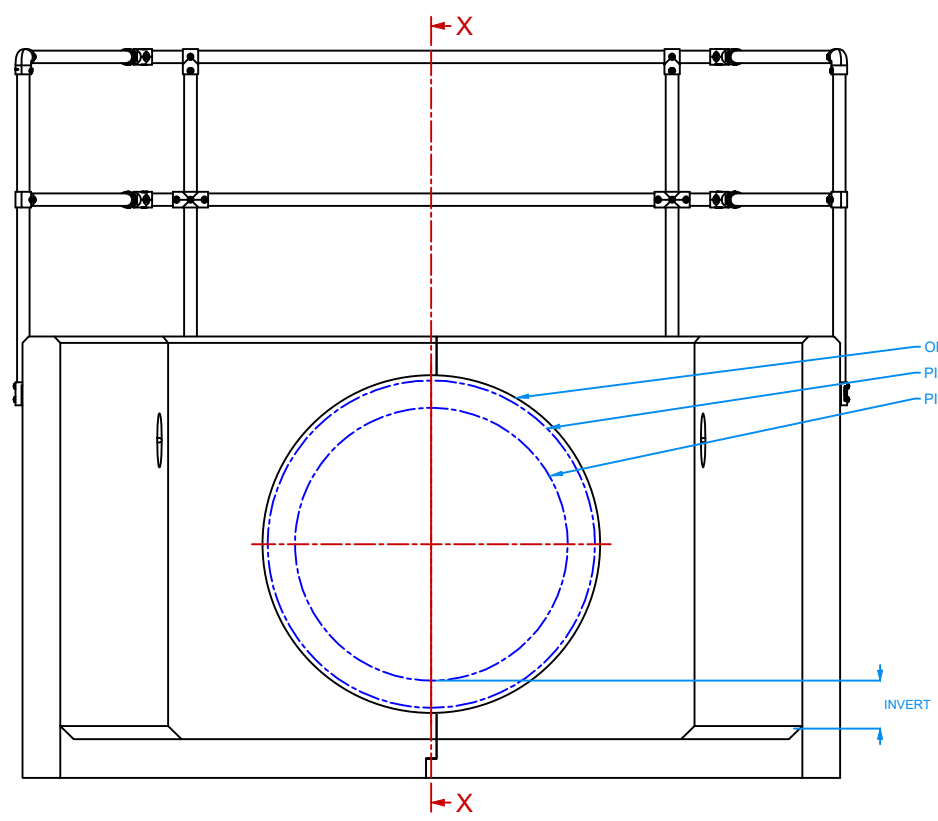

VIEW: FRONT

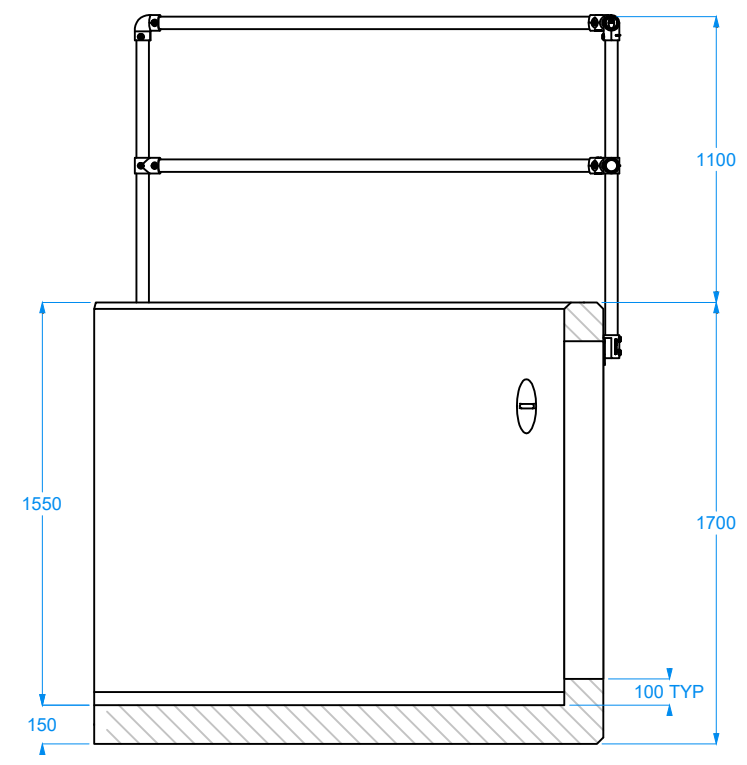

VIEW: SECTION

**STANDARD FEATURES**

**OPENING SIZE GUIDE**

Ø1300mm  
MAXIMUM  
OPENING

TYPICAL MAXIMUM PIPE SIZES\*  
PLASTIC TWINWALL ID: Ø1050mm  
CONCRETE ID: Ø1050mm

**CUSTOM DESIGN**  
BESPOKE SOLUTIONS...

- CONCRETE
- STEELWORK
- HANDRAILS
- FLOW CONTROL

100

YEAR  
DESIGN LIFE

**CAST-IN S/S SOCKETS**  
ACCURATE ALIGNMENT TO JOINT  
FITTINGS & OPTIONAL FEATURES

**OPTIONAL FEATURES**

**TOE BEAM RANGE**

• VARIOUS SIZE OPTIONS ARE AVAILABLE

**CONCRETE COLOURS**

• 24 COLOURS AVAILABLE IN RANGE FOR BLENDING ITEM WITH LOCAL ENVIRONMENT

**GRATINGS & TRASH SCREENS**

FACTORY FITTED AS STANDARD \*WHERE PRACTICAL / SAFE FOR TRANSPORT

- FULLY WELDED, HOT DIP GALVANISED STEEL & S/S FIXINGS AS STANDARD

- CLOSE COUPLED
- SFA / SSG OUTFALL GRILLE
- SLOPED
- CRANKED

**KEE KLAMP HANDRAILS**

FACTORY FITTED AS STANDARD \*WHERE PRACTICAL / SAFE FOR TRANSPORT

- KEE KLAMP #8 AS STANDARD
- FULLY SIDED (CODE: K30)
- HALF WING (CODE: K50)
- BACK ONLY (CODE: K00)

**FLOW CONTROL DEVICES**

FACTORY FITTED (WHERE PRACTICAL / SAFE FOR TRANSPORT) AS STANDARD

- S/S FIXINGS & RUBBER SEALS / SEALANTS AS STANDARD

- FLAP VALVES
- PENSTOCKS
- ORIFICE PLATES
- BAFFLE BLOCKS

**ALUMINIUM STOPLOG SYSTEM**

CHANNELS FACTORY FITTED AS STANDARD \* WHERE PRACTICAL / SAFE FOR TRANSPORT

- VARIOUS BOARD HEIGHT / TYPES AVAILABLE
- LOCKING BRACKETS & T-KEY KITS SUPPLIED, S/S FIXINGS & RUBBER SEALS AS STANDARD

**DRAWING NOTES**

- All dimensions in mm U.O.S.
- All measurements ±1mm.
- DO NOT SCALE DRAWING.

**SPECIFICATION INFORMATION**

- Opening in back wall cast to suit outer dimension of pipe.
- Invert level of pipe can be set to your specification.

**HEADWALL INSTALLATION**

Units should be bedded on minimum 150mm thick well compacted Class 6N or 6K\* well graded granular material with 50mm topping of fine material (Class 6L\*) to ensure units are level and stable. \*Manual of contract documents for Highway Works: Volume (MCHW1) specification for Highway Works, Series 600 (Nov 09).

**HANDLING**

A. Weight of concrete is based on 2.4 tonne/m<sup>3</sup> +5% is recommended for sizing lifting equipment.

B. All lifting points shall be used as specified below

C. Unit to be lifted as per lifting diagram.

**CONCRETE**

A. Mix ref: Self-compacting DC4 / DS4 Mix.

B. Lifting strength based on 2 cubes = 20N/mm<sup>2</sup>.

C. Characteristic 28 day cube strength = 50N/mm<sup>2</sup>.

D. Concrete provides Design Chemical Class 4 (DC4) to special Digest 1, Table F2.

**REINFORCEMENT**

A. Reinforcement to BS EN 13369.

B. Scheduling, dimensions, bends & cutting to BS8666.

C. Cage to be machine tied with steel wire.

**MANUFACTURE**

A. Manufacture to BS EN 15258:2008 precast concrete products retaining wall elements, factory production control certificate 0086-CPR-650448 & BS EN 13369.

B. Tolerances to BS EN 13369 clause 4.3.1.1.

C. Finishing:

Class	Top	Sides	Rear	Rear of Backwall
	A	A	A	Self-Levelled

D. Marking. Units shall be indelibly marked to show:

- Mould reference code.
- De-mould date.
- Job reference number & unique product number.
- Unit weight (kg).

**DESIGN**

A. Concrete structure designed to Eurocode 2.

B. JKH have designed concrete units only, the site conditions should be assessed for suitability by the scheme designer

C. Units are designed to withstand a vertical live load surcharge of 10kN/m<sup>2</sup>.

D. Weight of soil = 18kN/m<sup>2</sup>.

E. Angle of internal friction = 30 Deg.

F. Design Life as table below \* (all cover sizes in mm).

Design Life	>50 years, 100mm Wall Thickness		>100 years, 150mm Wall Thickness	
	Min Size Cover for All Faces	Max Size Cover	Min Size Cover	Max Size Cover
	33	28	38	55
			50	63

\*Design life of >100 years can be extended to >120 years with Bitumen coating application

Exposure Classification	Exposure induced by Carbonation	Corrosion induced by Chloride	Freeze/thaw attack	Chemical attack
All Faces	XC3/4	XD3	XF4	XA3

**FABRICATION SPECIFICATION**

A. Manufacture IAW EN 1090-2 EXC CLASS 1

B. Material grade is to be: BS EN 10025 S275

C. Welding to IAW EN 1090-2 PARA 7.5.4 - 7.5.18

D. All fillet & butt welds to have minimum throat thickness of 6mm and joints fully welded where possible.

E. Ensure vertical flats fully welded both sides where possible

F. All sharp edges and burrs are to be removed.

G. Remove all weld splatter.

H. Holes by punching are permitted with reaming.

I. Galvanising process after fabrication to BS EN ISO1461.

**HANDRAIL SPECIFICATION**

A. Kee Klamp® Galvanised Size 8 Fittings.

B. Size 8 48.3mm OD 3.2mm Wall Thickness Galvanised Medium Duty Tube to BS EN 10255

C. 360N/m Design Load as stated in BS 8118, BS 6180, BS 6399 & BS 7818, Civil Engineering Specification for the Water Industry (CESWI) 7th Edition Clause 2.60 Handrails & Balusters & The Engineering Equipment and Materials Users' Association (EEMUA) Publication 105 7th Edition Factory Stairways, Ladders and Handrails.

D. Other design loads available on request.

E. GRP/FRP Handrails also available.

ADDRESS: JKH LIMITED  
CHISWICK AVENUE  
MILDENHALL  
IP28 7AY

WEBSITE: [www.jkhld.co.uk](http://www.jkhld.co.uk)  
EMAIL: [sales@jkhld.co.uk](mailto:sales@jkhld.co.uk)  
TEL: 01638 713795

**PROPRIETARY & CONFIDENTIAL** Information contained on this drawing is the sole property of JKH Drainage Units Ltd. Any reproduction in part or as a whole without the written permission of JKH Drainage Units Ltd is strictly prohibited.

**DRAWING TITLE:**

**XR2000 C HEAWDALL  
STANDARD & OPTIONAL FEATURES**

**TOTAL WEIGHT (CASTINGS ONLY):** 5050 kg

**CONCRETE MIX DESIGN:**

**CEMENT  
REDUCTION ↓ -46%**

DRAWN: OB | ISSUE #: 01 | SHEET #: 1 of 1 | DATE: 10/07/25  
DRAWING #:  
**XR2000C**

**STANDARD FEATURES**

**OPENING SIZE GUIDE**

Ø1850mm  
MAXIMUM  
OPENING

TYPICAL MAXIMUM PIPE SIZES\*  
PLASTIC TWINWALL I/D: Ø1500mm  
CONCRETE I/D: Ø1500mm

**CUSTOM DESIGN  
BESPOKE SOLUTIONS...**

- CONCRETE
- STEELWORK
- HANDRAILS
- FLOW CONTROL

**100  
YEAR  
DESIGN LIFE**

**CAST-IN S/S SOCKETS**  
ACCURATE ALIGNMENT TO JOINT  
FITTINGS & OPTIONAL FEATURES

**OPTIONAL FEATURES**

**TOE BEAM RANGE**

• VARIOUS SIZE  
OPTIONS ARE  
AVAILABLE

**CONCRETE COLOURS**

• 24 COLOURS AVAILABLE IN  
RANGE FOR BLENDING ITEM  
WITH LOCAL ENVIRONMENT

**GRATINGS & TRASH SCREENS**

FACTORY FITTED AS STANDARD \*WHERE PRACTICAL / SAFE FOR TRANSPORT

- FULLY WELDED, HOT DIP GALVANISED STEEL & S/S FIXINGS AS STANDARD

• CLOSE  
COUPLED

• SFA / SSG  
OUTFALL GRILLE

• SLOPED

• CRANKED

**KEE KLAMP HANDRAILS**

FACTORY FITTED AS STANDARD \*WHERE PRACTICAL / SAFE FOR TRANSPORT

- KEE KLAMP #8 AS STANDARD
- FULLY SIDED (ICODE: K30)
- HALF WING (ICODE: K50)
- BACK ONLY (ICODE: K00)

**FLOW CONTROL DEVICES**

FACTORY FITTED (WHERE PRACTICAL / SAFE FOR TRANSPORT) AS STANDARD

- S/S FIXINGS & RUBBER SEALS / SEALANTS AS STANDARD

• FLAP VALVES

• PENSTOCKS

• ORIFICE  
PLATES

• BAFFLE  
BLOCKS

**ALUMINIUM STOPLOG SYSTEM**

CHANNELS FACTORY FITTED AS STANDARD \* WHERE PRACTICAL / SAFE FOR TRANSPORT

- VARIOUS BOARD HEIGHT / TYPES AVAILABLE
- LOCKING BRACKETS & T-KEY KITS SUPPLIED, S/S FIXINGS & RUBBER SEALS AS STANDARD

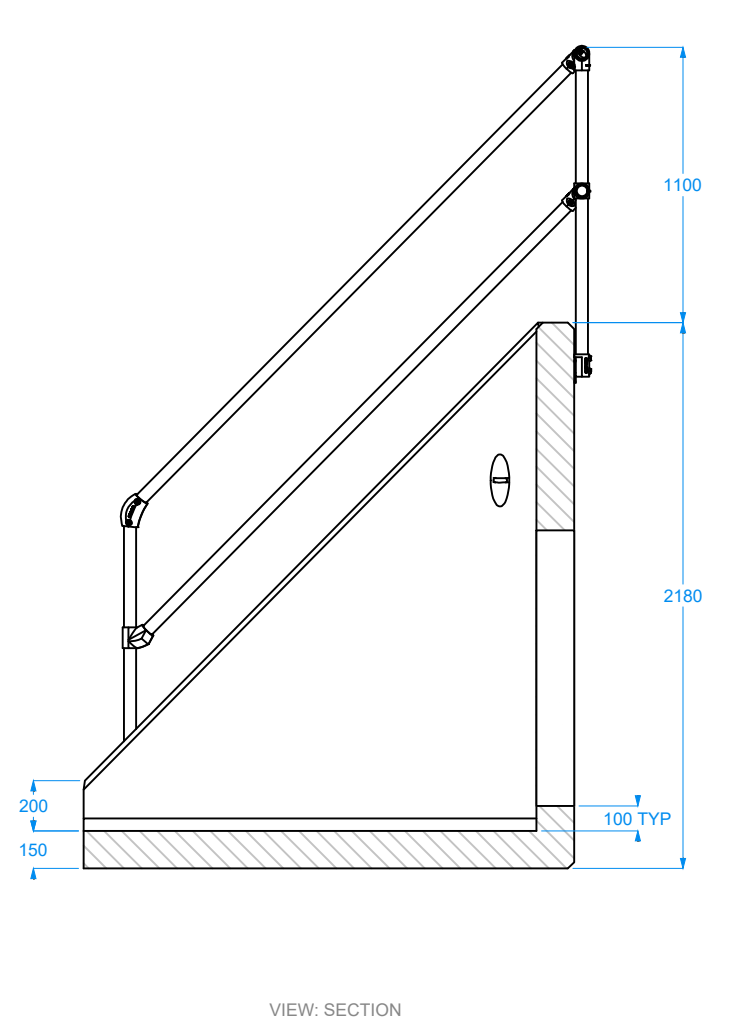
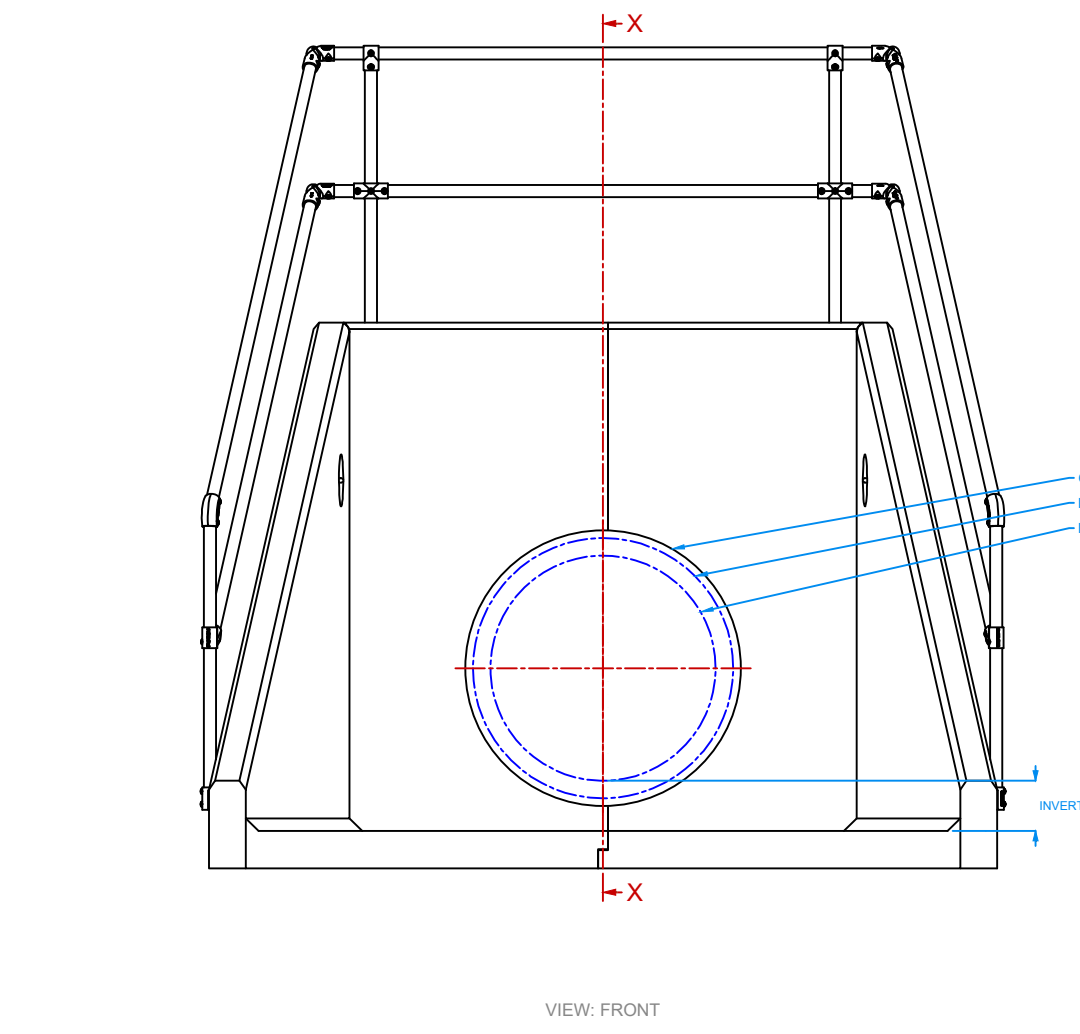
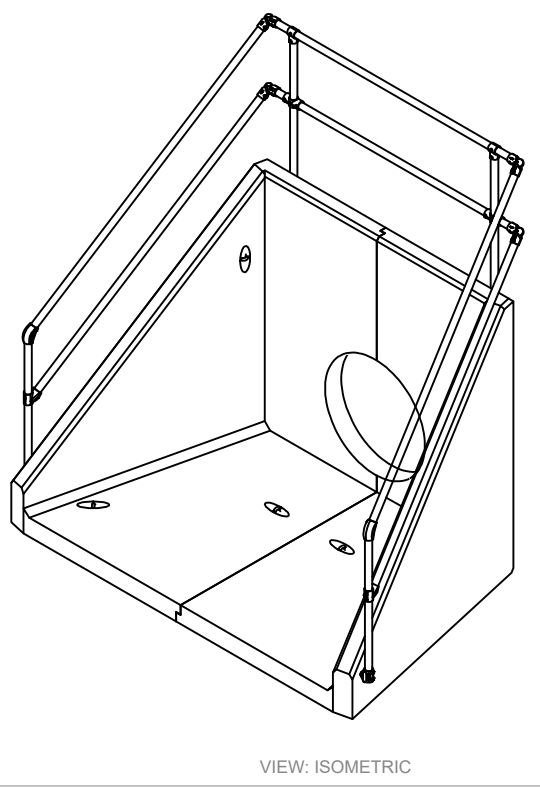
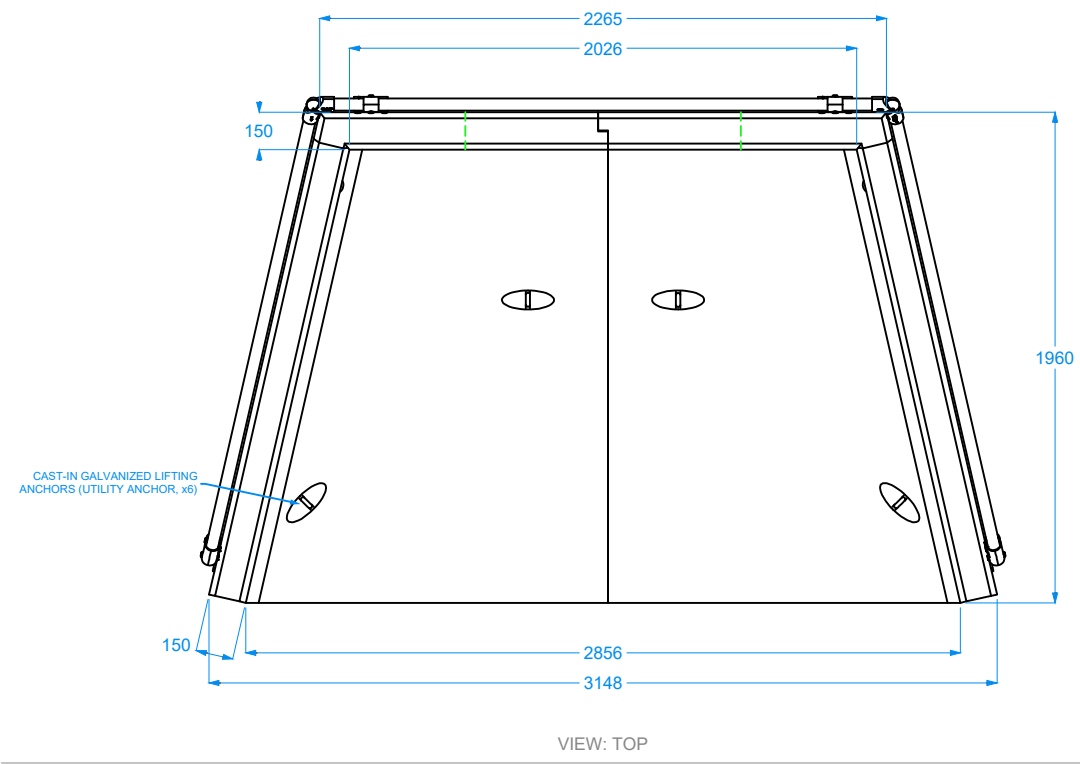

**DRAWING NOTES**

- All dimensions in mm U.O.S.
- All measurements ±1mm.
- DO NOT SCALE DRAWING.

**SPECIFICATION INFORMATION**

- Opening in back wall cast to suit outer dimension of pipe.
- Invert level of pipe can be set to your specification.

**HEADWALL INSTALLATION**

Units should be bedded on minimum 150mm thick well compacted Class 6N or 6K\* well graded granular material with 50mm topping of fine material (Class 6L\*) to ensure units are level and stable. \*Manual of contract documents for Highway Works: Volume (MCHW1) specification for Highway Works, Series 600 (Nov 09).

**HANDLING**

A. Weight of concrete is based on 2.4 tonne/m<sup>3</sup> +5% is recommended for sizing lifting equipment.

B. All lifting points shall be used as specified below

C. Unit to be lifted as per lifting diagram.

**CONCRETE**

A. Mix ref: Self-compacting DC4 / DS4 Mix.

B. Lifting strength based on 2 cubes = 20N/mm<sup>2</sup>.

C. Characteristic 28 day cube strength = 50N/mm<sup>2</sup>.

D. Concrete provides Design Chemical Class 4 (DC4) to special Digest 1, Table F2.

**REINFORCEMENT**

A. Reinforcement to BS EN 13369.

B. Scheduling, dimensions, bends & cutting to BS8666.

C. Cage to be machine tied with steel wire.

**MANUFACTURE**

A. Manufacture to BS EN 15258:2008 precast concrete products retaining wall elements, factory production control certificate 0086-CPR-650448 & BS EN 13369.

B. Tolerances to BS EN 13369 clause 4.3.1.1.

C. Finishing:

Class	Top	Sides	Rear	Rear of Backwall
	A	A	A	Self-Levelled
Class	A	A	A	Self-Levelled

D. Marking. Units shall be indelibly marked to show:

- Mould reference code.
- De-mould date.
- Job reference number & unique product number.
- Unit weight (kg).

**DESIGN**

A. Concrete structure designed to Eurocode 2.

B. JKH have designed concrete units only, the site conditions should be assessed for suitability by the scheme designer

C. Units are designed to withstand a vertical live load surcharge of 10kN/M<sup>2</sup>.

D. Weight of soil = 18kN/M<sup>2</sup>.

E. Angle of internal friction = 30 Deg.

F. Design Life as table below \* (all cover sizes in mm).

Design Life	>50 years, 100mm Wall Thickness		>100 years, 150mm Wall Thickness	
	Block Size Cover	Min Size Cover	Block Size Cover	Min Size Cover
Minimum Cover for All Faces	33	28	38	33
Max Size Cover	50	50	50	63

Exposure Classification	Exposure induced by Carbonation	Corrosion induced by Chloride	Freeze/thaw attack	Chemical attack
	All Faces	XC3/4	XD3	XF4

**FABRICATION SPECIFICATION**

A. Manufacture IAW EN 1090-2 EXC CLASS 1

B. Material grade is to be: BS EN 10025 S275

C. Welding to IAW EN 1090-2 PARA 7.5.4 - 7.5.18

D. All fillet & butt welds to have minimum throat thickness of 6mm and joints fully welded where possible.

E. Ensure vertical flats fully welded both sides where possible

F. All sharp edges and burrs are to be removed.

G. Remove all weld splatter.

H. Holes by punching are permitted with reaming.

I. Galvanising process after fabrication to BS EN ISO1461.

**HANDRAIL SPECIFICATION**

A. Kee Klamp® Galvanised Size 8 Fittings.

B. Size 8 48.3mm OD 3.2mm Wall Thickness Galvanised Medium Duty Tube to BS EN 10255

C. 360N/m Design Load as stated in BS 8118, BS 6180, BS 6399 & BS 7818, Civil Engineering Specification for the Water Industry (CESWI) 7th Edition Clause 2.60 Handrails & Balusters & The Engineering Equipment and Materials Users' Association (EEMUA) Publication 105 7th Edition Factory Stairways, Ladders and Handrails.

D. Other design loads available on request.

E. GRP/FRP Handrails also available.

ADDRESS: JKH LIMITED  
CHISWICK AVENUE  
MILDENHALL  
IP28 7AY

WEBSITE: [www.jkhlimited.co.uk](http://www.jkhlimited.co.uk)  
EMAIL: [sales@jkhlimited.co.uk](mailto:sales@jkhlimited.co.uk)  
TEL: 01638 713795

**PROPRIETARY & CONFIDENTIAL** Information contained on this drawing is the sole property of JKH Drainage Units Ltd. Any reproduction in part or as a whole without the written permission of JKH Drainage Units Ltd is strictly prohibited.

**DRAWING TITLE:**

**XR2000 C LW HEAWDALL  
STANDARD & OPTIONAL FEATURES**

**TOTAL WEIGHT (CASTINGS ONLY):** 6275 kg

**CONCRETE MIX DESIGN:**

**eco 1**

**CEMENT  
REDUCTION ↓ -46%**

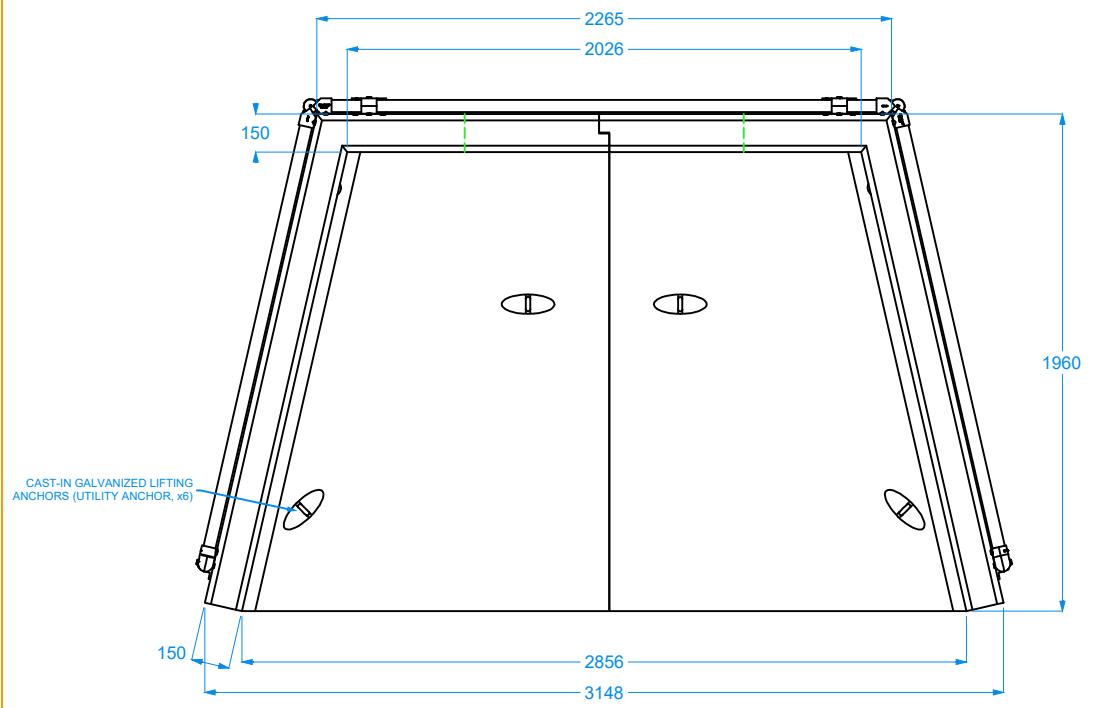

VIEW: TOP

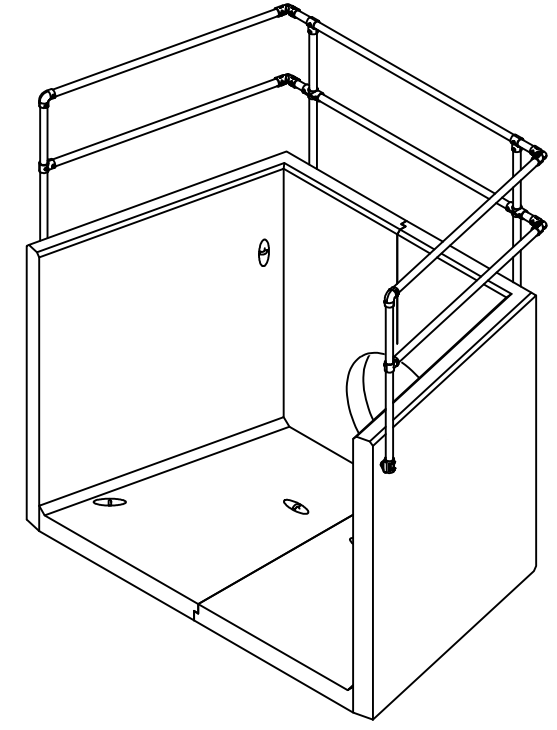

VIEW: ISOMETRIC

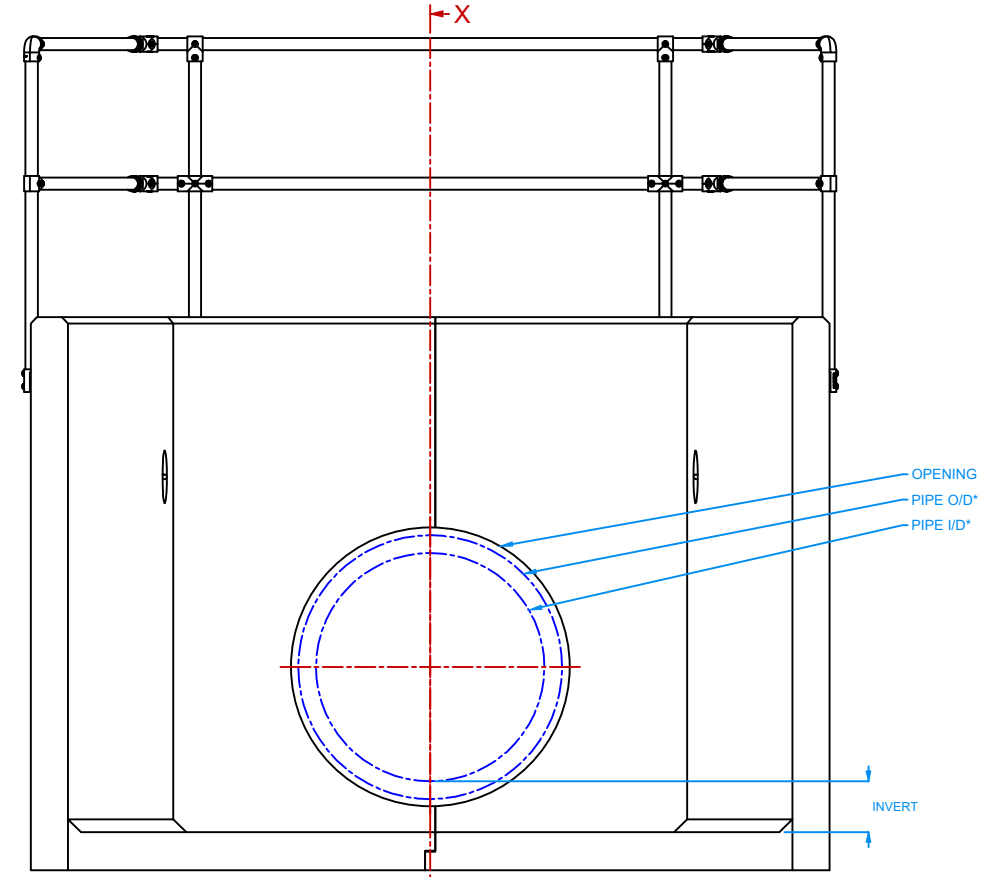

VIEW: FRONT

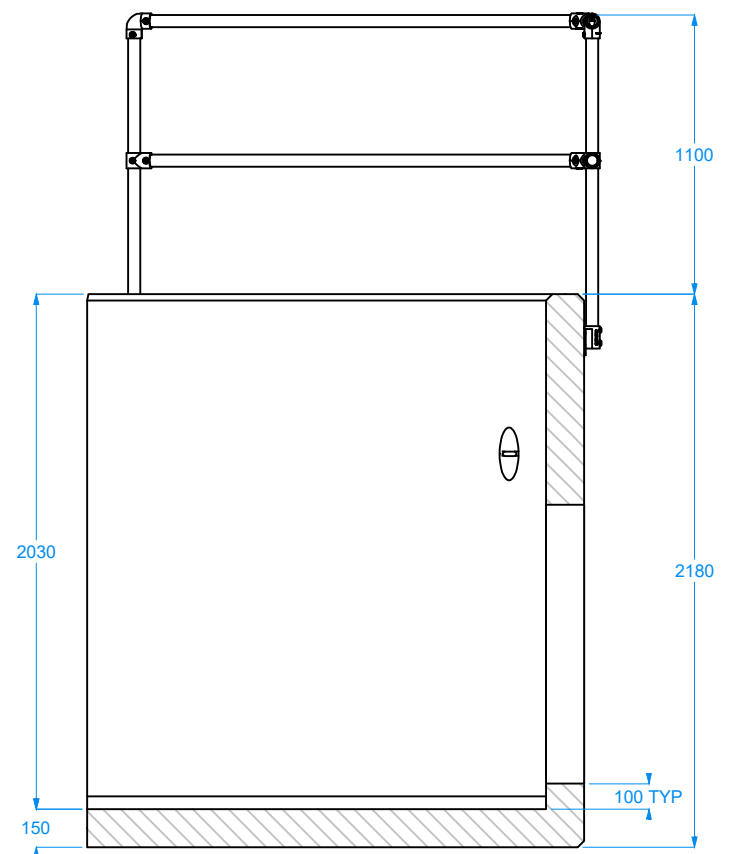

VIEW: SECTION

**STANDARD FEATURES**

**OPENING SIZE GUIDE**

Ø1850mm  
MAXIMUM  
OPENING

TYPICAL MAXIMUM PIPE SIZES:  
PLASTIC TWINWALL ID: Ø1500mm  
CONCRETE ID: Ø1500mm

**CUSTOM DESIGN**  
BESPOKE SOLUTIONS ...

- CONCRETE
- STEELWORK
- HANDRAILS
- FLOW CONTROL

**100  
YEAR  
DESIGN LIFE**

**CAST-IN S/S SOCKETS**  
ACCURATE ALIGNMENT TO JOINT  
FITTINGS & OPTIONAL FEATURES

**OPTIONAL FEATURES**

**TOE BEAM RANGE**

- VARIOUS SIZE OPTIONS ARE AVAILABLE

**CONCRETE COLOURS**

- 24 COLOURS AVAILABLE IN RANGE FOR BLENDING ITEM WITH LOCAL ENVIRONMENT

**GRATINGS & TRASH SCREENS**

FACTORY FITTED AS STANDARD \*WHERE PRACTICAL / SAFE FOR TRANSPORT

- FULLY WELDED, HOT DIP GALVANISED STEEL & S/S FIXINGS AS STANDARD

- CLOSE COUPLED
- SFA / SSG OUTFALL GRILLE
- SLOPED
- CRANKED

**KEE KLAMP HANDRAILS**

FACTORY FITTED AS STANDARD \*WHERE PRACTICAL / SAFE FOR TRANSPORT

- KEE KLAMP #8 AS STANDARD
- FULLY SIDED (CODE: K30)
- HALF WING (CODE: K50)
- BACK ONLY (CODE: K00)

**FLOW CONTROL DEVICES**

FACTORY FITTED (WHERE PRACTICAL / SAFE FOR TRANSPORT) AS STANDARD

- S/S FIXINGS & RUBBER SEALS / SEALANTS AS STANDARD

- FLAP VALVES
- PENSTOCKS
- ORIFICE PLATES
- BAFFLE BLOCKS

**ALUMINIUM STOPLOG SYSTEM**

CHANNELS FACTORY FITTED AS STANDARD \*WHERE PRACTICAL / SAFE FOR TRANSPORT

- VARIOUS BOARD HEIGHT / TYPES AVAILABLE
- LOCKING BRACKETS & T-KEY KITS SUPPLIED, S/S FIXINGS & RUBBER SEALS AS STANDARD